

Drive Controlled Pump

Energy-Efficient Hydraulic System Solutions



ENGINEERING YOUR SUCCESS.



WARNING – USER RESPONSIBILITY

FAILURE OR IMPROPER SELECTION OR IMPROPER USE OF THE PRODUCTS DESCRIBED HEREIN OR RELATED ITEMS CAN CAUSE DEATH, PERSONAL INJURY AND PROPERTY DAMAGE.

This document and other information from Parker-Hannifin Corporation, its subsidiaries and authorized distributors provide product or system options for further investigation by users having technical expertise.

The user, through its own analysis and testing, is solely responsible for making the final selection of the system and components and assuring that all performance, endurance, maintenance, safety and warning requirements of the application are met. The user must analyze all aspects of the application, follow applicable industry standards, and follow the information concerning the product in the current product catalog and in any other materials provided from Parker or its subsidiaries or authorized distributors.

To the extent that Parker or its subsidiaries or authorized distributors provide component or system options based upon data or specifications provided by the user, the user is responsible for determining that such data and specifications are suitable and sufficient for all applications and reasonably foreseeable uses of the components or systems.

Offer of Sale

Please contact your Parker representation for a detailed "Offer of Sale".

Description	Page
Drive Controlled Pump Systems	
Introduction	4
System components	5
Quick selection table	6
AC20F ordering code	7
Option cards	8
DCP ordering code	10
AC20F drive	12
Parker Drive System Explorer	14
Motors	
Standard asynchronous motors	15
Pumps	
Vane pumps	16
Axial piston pumps	17
Dimensions	
Vane pump with standard asynchronous motor	18
Axial piston pump with standard asynchronous motor	20
Double vane pump with standard asynchronous motor	24

The Drive Controlled Pump system solutions from Parker are variable-speed hydraulic pump systems. They essentially consist of an AC drive unit (frequency controller and electronics), an asynchronous motor as well as a hydraulic pump. They enable the central, regulated hydraulic supply of all drives. Thus they provide the exact power that is required in the cycle at all times.

The controller continuously records target values for the volume flow and/or pressure of the machine control system and compares them to actual pressure value. The drive speed of the electric motor is regulated so that the pump provides the exact amount of oil required to achieve the target value.

With the Drive Controlled Pump, Parker optionally employs vane pumps or axial piston pumps or combinations of both.

The vane pump represents the ideal basis for systems with fixed displacement pumps. Her minimum speed increases from zero proportional to pressure up to 300 rpm at maximum pressure. Thanks to the very wide range of speed up to 3000 rpm and the high operating pressures of up to 320 bar, this system solution can be tuned exactly to a customer's specific requirements. The robust double lip design makes the pump impervious to particle contamination and maintains a high degree of efficiency in the long term.

The axial piston pump is utilized if high peak pressures are introduced or if high pressures must be maintained for long periods. The housings increased rigidity ensures low vibration and therefore reduces the noise level. The reduced pressure and volume flow pulsation also reduces the load on the piping system.

Features

- Suitable for 400 V supply
- Change-over pressure/volume flow control
- Optimum dimensioning of all components using the Parker DriveCreator software
- Standard interfaces for simple conversion of conventional pump systems
- Dual pump systems for larger volume flow possible – also as combination of variable and fixed displacement pump systems
- High precision and dynamic operation for flow and pressure control
- High energy efficiency through optimum adjustment to cycle requirements
- Low noise emissions through optimized pump design and speed adjustment

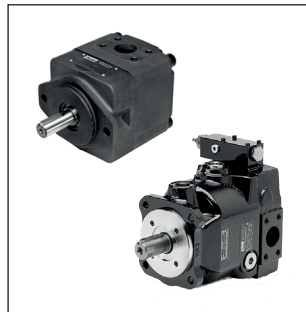
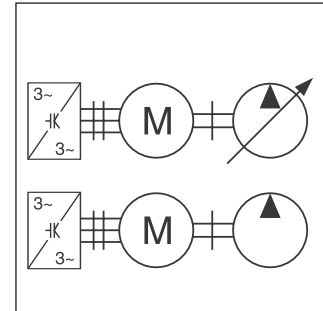
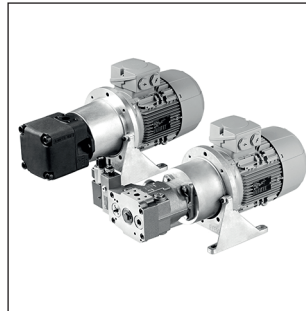

The DCP combinations fulfill the latest efficiency standards and all requirements of european directive EU 2021/341, valid July, 1st 2023.

Recommended fluids

We recommend high-quality mineral hydraulic fluids: HLP oils as per DIN 51524. For general applications, the Bruggen value should be at least 30 N/mm²; 50 N/mm² for heavy-duty systems (measured as per DIN 51347-2).

Under normal conditions, the viscosity should be between 16 and 100 mm²/s /cSt). Maximum start-up viscosity is 800 mm²/s (cSt).

The fluid must have a purity in conformance with ISO 4406:1999. The filter elements must also conform to ISO standards. For systems with maximum service life: purity level 18/16/13 in accordance with ISO 4406:1999; otherwise, purity level 20/18/15 (19/17/14 for vane pumps) in accordance with ISO 4406:1999.

Components of the drive-controlled pump system

1. AC Drive Controller
 - AC20
2. Motor
 - Asynchronous standard motor
3. Pump
 - Vane pump T7, catalogue HY29-0001, or
 - Axial piston pump PVplus, catalogue HY30-3245, or
 - Combination of vane pump and axial piston pump
 - Mounting accessories for motor pump assembly ¹⁾:
 - Coupling
 - Pump bellhousing
 - Pump flange
4. Accessories that may be required ²⁾
 - Shield connection
 - Power cables
 - Sensor cables
 - Braking resistor
 - Mains filters
 - Pressure transducer

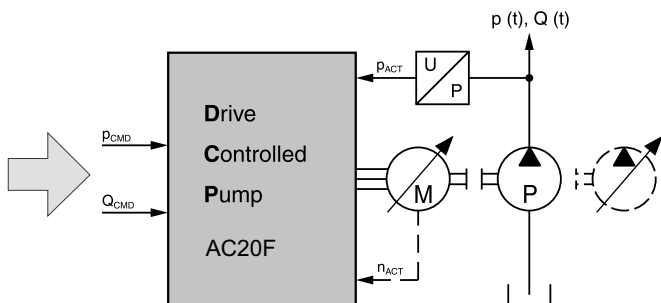

Further combinations in addition to those contained in this catalogue are available upon request. Detailed information on all Parker components can be found in the individual product catalogues (see above).

Parker DriveCreator

For optimum yet simple selection and dimensioning of the components Parker offers a unique software tool: the Parker DriveCreator.

Firstly, the cycle data (cylinder speed and load or pressure and volume flow) is entered. Subsequently, the optimum pump or combination of pumps is selected using this data, and then motor and drive suitable for the power consumption.

The Parker DriveCreator calculates the best combination of components possible with the highest degree of energy efficiency.

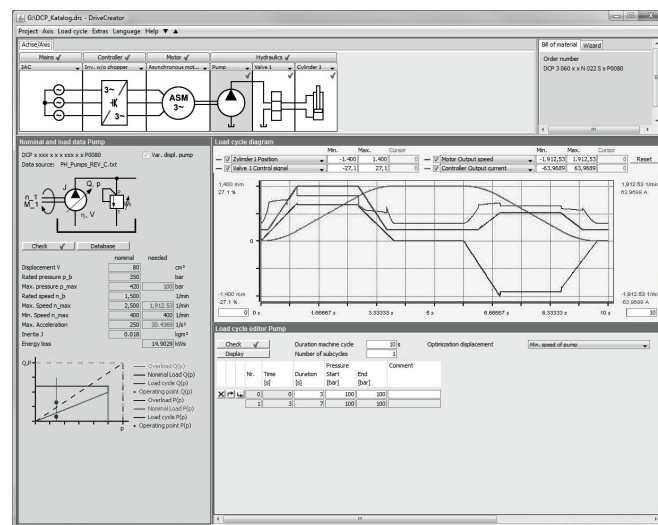

¹⁾ Dependent on the selected motor-pump combination.
²⁾ Not included in delivery.

Quick selection table

Q _{max} @ 2000 rpm	Max pressure [bar] required												Size	
	Pump Code	25	50	75	100	125	150	175	200	225	250	275		
19.6	B0003	N2P2 2-0090		N003 3-0120		N004 3-0120	N006 3-0170		N008 4-0230		N011 4-0320		Motor Drive	
25.6	B0004	N003 3-0120		N004 3-0120	N006 3-0170	N008 4-0230		N011 4-0320		N015 5-0380		Motor Drive		
31.8	B0005	N2P2 2-0090	N004 3-0120	N006 3-0170	N008 4-0230	N011 4-0320		N015 5-0380					Motor Drive	
39.6	B0006	N2P2 2-0090	N004 3-0120	N006 3-0170	N008 4-0230	N011 4-0320		N015 5-0380					Motor Drive	
45	B0007	N2P2 2-0090	N006 3-0170	N008 4-0230	N011 4-0320		N015 5-0380						Motor Drive	
49.8	B0008	N003 3-0120	N008 4-0230		N011 4-0320	N015 5-0380							Motor Drive	
56	B0009		N006 3-0170	N011 4-0320		N015 5-0380		N019 5-0440	N022 5-0600	N030 6-0750			Motor Drive	
63.6	B0010		N008 4-0230	N011 4-0320	N015 5-0380		N022 5-0600		N030 6-0750		N045 7-0110		Motor Drive	
70	B0011		N008 4-0230	N011 4-0320	N015 5-0380	N019 5-0440	N022 5-0600		N030 6-0750		N045 7-1100		Motor Drive	
82	B0012		N008 4-0230	N011 4-0320	N015 5-0380	N022 5-0600		N030 6-0750		N045 7-1100			Motor Drive	
90	B0014	N006 3-0170	N011 4-0320	N015 5-0380	N019 5-0440	N022 5-0600	N030 6-0750		N037 6-0900		N045 7-1100		Motor Drive	
100	B0015	N006 3-0170	N011 4-0320	N015 5-0380	N019 5-0440	N030 6-0750		N037 6-0900		N045 7-1100		Motor Drive		
110	D0017		N011 4-0320	N015 5-0380	N022 5-0600	N030 6-0750		N045 7-1100		N055 7-1500		Motor Drive		
132	D0020		N015 5-0380	N019 5-0440	N030 6-0750		N045 7-1100		N055 7-1500		N075 8-1800		Motor Drive	
140	D0022		N015 5-0380	N022 5-0600	N030 6-0750	N037 6-0900	N045 7-1100		N055 7-1500		N075 8-1800		Motor Drive	
162	D0024		N015 5-0380	N022 5-0600	N030 6-0750	N037 6-0900	N045 7-1100	N055 7-1500		N075 8-1800			Motor Drive	
180	D0028	N011 4-0320	N019 5-0440	N030 6-0750	N045 7-1100		N055 7-1500		N075 8-1800		N090 8-2200		Motor Drive	
198.4	D0031	N011 4-0320	N019 5-0440	N030 6-0750	N045 7-1100		N055 7-1500		N075 8-1800		N090 8-2200		N110 8-2650	Motor Drive
226.8	D0035	N011 4-0320	N022 5-0600	N045 7-1100		N055 7-1500		N075 8-1800		N090 8-2200		N110 8-2650		Motor Drive
241.2	D0038	N015 5-0380	N022 5-0600	N045 7-1100		N055 7-1500		N075 8-1800		N090 8-2200		N110 8-2650		Motor Drive
275	D0042	N015 5-0380	N030 6-0750	N045 7-1100	N055 7-1500	N075 8-1800		N090 8-2200		N110 8-2650	N132 9-3200		Motor Drive	
284.8	E0045		N037 6-0900	N045 7-1100	N075 8-1800		N090 8-2200		N110 8-2650			Motor Drive		
317	E0050		N037 6-0900	N045 7-1100	N075 8-1800		N090 8-2200		N110 8-2650		N132 9-3200		Motor Drive	
329.6	E0052		N037 6-0900	N045 7-1100	N075 8-1800		N090 8-2200		N110 8-2650		N132 9-3200		Motor Drive	
342	E0054		N037 6-0900	N055 7-1500	N075 8-1800	N090 8-2200		N110 8-2650		N132 9-3200			Motor Drive	
366.6	E0057		N045 7-1100	N075 8-1800		N090 8-2200		N110 8-2650		N132 9-3200		N160 10-3600		Motor Drive
393.4	E0062		N045 7-1100	N075 8-1800		N110 8-2650		N132 9-3200		N160 10-3600			Motor Drive	
426.6	E0066		N045 7-1100	N075 8-1800	N090 8-2200	N110 8-2650		N132 9-3200		N160 10-3600			Motor Drive	
454.2	E0072		N045 7-1100	N075 8-1800	N090 8-2200	N110 8-2650		N132 9-3200		N160 10-3600			Motor Drive	

Selection of components

The quick selection shown takes into account known efficiency of the components, but cannot optimally cover all operating purposes and applications. An optimized interpretation requires detailed knowledge of the load cycle. Then an ideal component selection can be made with our calculation tool DriveCreator. We always recommend a detailed interpretation with the well known parameters. Our experts will be pleased to advise you.

Based on our experience, we urgently recommend choosing the nominal output of the FU a level above the

engine. For very dynamic operation and strong acceleration processes, at least the next higher performance level must be selected. Likewise in the event of expected pressure tips.

Please note that the engine usually has a high level of overload potential. This performance always requires a sufficiently dimensioned frequency converter that can also provide the service. With long operation in the area of low speeds (<800 rpm) and high pressure loads, external cooled engines must usually be selected.

Ordering code AC20 Advanced hydraulic purpose AC drive

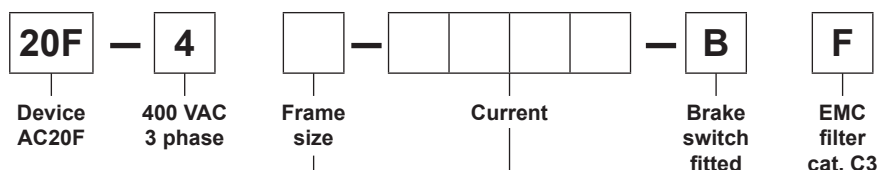

Code		Current [A]
2	- 0040	Frame 2 - 4 A (1.5 kW)
2	- 0065	Frame 2 - 6.5 A (2.2 kW)
2	- 0090	Frame 2 - 9 A (4.0 kW)
3	- 0120	Frame 3 - 12 A (5.5 kW)
3	- 0170	Frame 3 - 17 A (7.5 kW)
4	- 0230	Frame 4 - 23 A (11 kW)
4	- 0320	Frame 4 - 32 A (15 kW)
5	- 0380	Frame 5 - 38 A (18.5 kW)
5	- 0440	Frame 5 - 44 A (22 kW)
5	- 0600	Frame 5 - 60 A (30 kW)
6	- 0750	Frame 6 - 75 A (37 kW)
6	- 0900	Frame 6 - 90 A (45 kW)
7	- 1100	Frame 7 - 110 A (55 kW)
7	- 1500	Frame 7 - 150 A (75 kW)
8	- 1800	Frame 8 - 180 A (90 kW)
8	- 2200	Frame 8 - 220 A (110 kW)
8	- 2650	Frame 8 - 265 A (132 kW)
9	- 3200	Frame 9 - 320 A (160 kW)
10	- 3600	Frame 10 - 360 A (180 kW)

Option cards

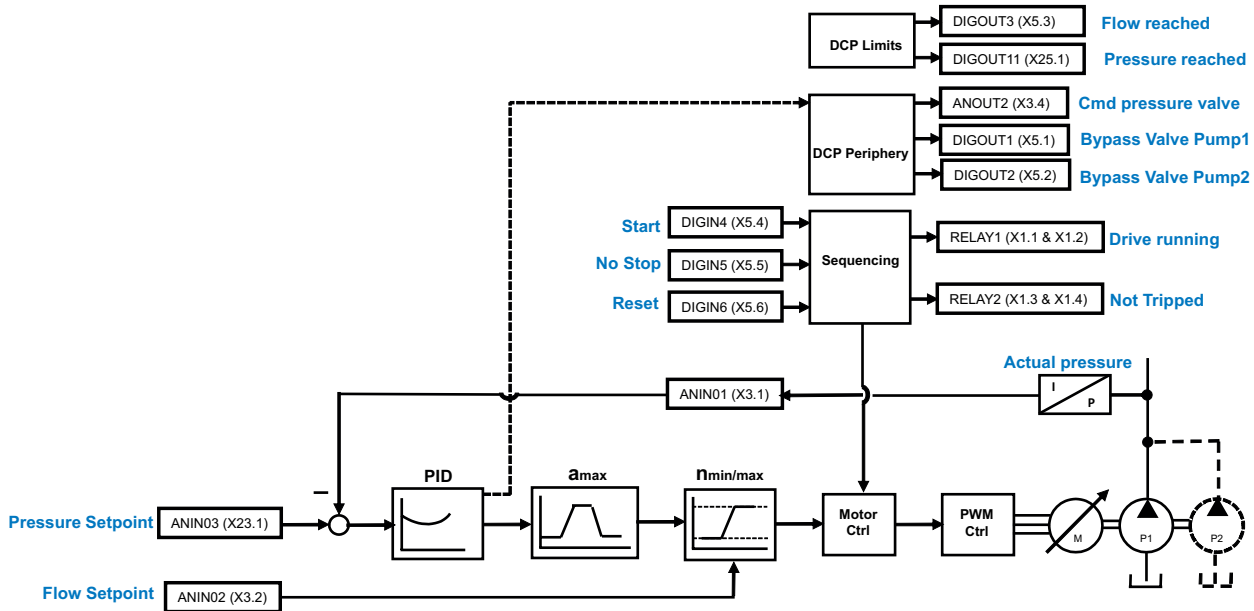

Application overview

Interface	Application					
	pQ Control	p Control	Q Control	eLCP	Accu charging mode	Power Unit Control
Analogue	2004-IO-00	—	—	2004-IO-00	—	2004-IO-00
CANopen	2003-CB-00			2003-CB-00 / 2004-IO-00		
EtherCAT	2003-EC-00			2003-EC-00 / 2004-IO-00		
EthernetIP	2003-IP-00			2003-IP-00 / 2004-IO-00		
Profibus	2003-PB-00			2003-PB-00 / 2004-IO-00		
Profinet	2003-PN-00			2003-PN-00 / 2004-IO-00		
Modbus RTU	2003-RS-00			2003-CB-00 / 2004-IO-00		

General purpose I/O (GPIO) option card

The general purpose I/O (GPIO) option module offers users the opportunity to expand the drives standard I/O capability, allowing more complex motor control solutions to be implemented.

The option can be fitted in either slot 1 or 2, and two options can be fitted at the same time to maximize the IO compliment. For example, two fitted IO options will give an additional 4 analogue inputs



2004-IO-00	GPIO Option
Analogue inputs	2x Analogue inputs ($\pm 10V$, 0-10V)
Analogue output	1x Analogue outputs ($\pm 10V$, 0-10V)
Digital I/O	Digital Input/Output 1 (24V configurable)
Reference voltages	+/- 10V References

Encoder Feedback Card

The HTTL pulse encoder feedback module allows an incremental encoder to be connected to the AC20, allowing users to take full advantage of closed-loop vector control.

The option can be fitted in either slot 1 or 2, and two identical options can be fitted at the same time, allowing for simple speed following applications.

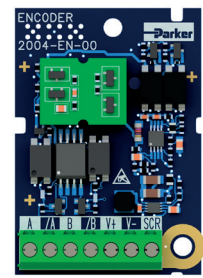

2004-EN-00	Encoder Feedback Option
Maximum input frequency	250 kHz per channel
Input format	Quadrature
Output supply voltage	5V, 12V, 15V, 20V

Communication Option Cards

2003-CB-00	CANopen communication interface
Supported Protocols	DS301 V4.02
Communication Speed	10 k, 20 k, 50 k, 125 k, 250 k, 500 k, 1 Mbps/s or automatically detected
Max. number of devices	127
Supported Messages	SDO, PDO, NMT, SYNC
2003-EC-00	EtherCAT communication interface
Supported Protocols	CANopen over EtherCAT (CoE) DS301 compliant
Communication Speed	100 Mbits/s
Max. number of devices	65534
Supported Messages	SDO, PDO, NMT, SYNC
2003-IP-00	Ethernet IP communication interface
Supported Protocols	Ethernet IP
Communication Speed	10/100 Mbits/s full/half duplex
Max. number of devices	Virtually unlimited
Supported Messages	Up to 256 bytes of consumed data and 256 bytes of produced data, CIP parameter object support, Explicit messaging
2003-PB-00	PROFIBUS DP-V1 communication interface
Supported Protocols	PROFIBUS-DP; Demand data and Data exchange
Communication Speed	Up to 12 Mbits/s; automatically detected
Max. number of devices	32 per segment, 126 total
Supported Messages	Up to 152 bytes cyclic I/O, 68 bytes class 1 and 2 acyclic data, 152 bytes configuration data. GSD file provided
2003-RS-00	RS485 / Modbus RTU communication interface
Supported Protocols	Modbus RTU
Communication Speed	1200 to 115200 bits/s
Max. number of devices	247
Supported Messages	Up to 256 bytes of cyclic I/O data in each direction
2003-PN-00	PROFINET I/O communication interface
Supported Protocols	PROFINET I/O generic device
Communication Speed	10/100 Mbits/s full/half duplex
Max. number of devices	Up to 128 submodules in total
Supported Messages	Up to 256 bytes of cyclic I/O in data in each direction



CANopen



EtherCAT



EtherNet/IP



PROFIBUS



Modbus



PROFINET

Ordering Code

Drive Controlled Pump

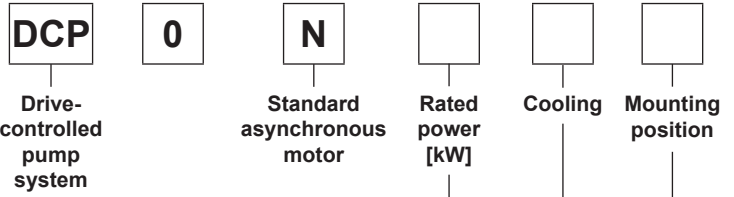

Rated power	
Code	[kW]
1P5	1.50
2P2	2.20
003	3.00
004	4.00
006	5.50
008	7.50
011	11.0
015	15.0
019	18.5
022	22.0
030	30.0
037	37.0
045	45.0
055	55.0
075	75.0
090	90.0
110	110.0
132	132.0
160	160.0

Code	Cooling
S	self vented
F	external vented

Code	Mounting position
0	horizontal (B5) with foot flange
1	horizontal (B35), motor with stand
2	vertical (V1), motor up, without protective cover

Pump type ¹⁾															
Vane pumps				Axial piston pumps				Double pump vane pumps				Double pump vane pumps			
T7B				PVplus				T7BB				T7EB			
Code		[cm ³ /U]		Code		[cm ³ /U]		Pump 1		Pump 2		Pump 1		Pump 2	
B	0003	9.8		P	0016	16		J	03	9.8		M	42	132.3	
B	0004	12.8		P	0020	20		J	04	12.8		M	45	142.4	
B	0005	15.9		P	0023	23		J	05	15.9		M	50	158.5	
B	0006	19.8		P	0028	28		J	06	19.8		M	52	164.8	
B	0007	22.5		P	0032	32		J	07	22.5		M	54	171.0	
B	0008	24.9		P	0040	40		J	08	24.9		M	57	183.3	
B	0009	28.0		P	0046	46		J	09	28.0		M	62	196.7	
B	0010	31.8		P	0063	63		J	10	31.8		M	66	213.3	
B	0011	35.0		P	0080	80		J	11	35.0		M	72	227.1	
B	0012	41.0		P	0092	92		J	12	41.0					
B	0014	45.0		P	0140	140		J	14	45.0					
B	0015	50.0		P	0180	180		J	15	50.0					
T7D				P				T7DB				T7ED			
Code		[cm ³ /U]		Code		[cm ³ /U]		Pump 1		Pump 2		Pump 1		Pump 2	
D	0017	55.0		P	0270	270		K	17	55.0		N	42	132.3	
D	0020	66.0		P	0360	360		K	20	66.0		N	45	142.4	
D	0022	70.3						K	22	70.3		N	50	158.5	
D	0024	81.1						K	24	81.1		N	52	164.8	
D	0028	90.0						K	28	90.0		N	54	171.0	
D	0031	99.2						K	31	99.2		N	57	183.3	
D	0035	113.4						K	35	113.4		N	62	196.7	
D	0038	120.6						K	38	120.6		N	66	213.3	
D	0042	137.5						K	42	137.6		N	72	227.1	
T7E															
E	0042	132.3													
E	0045	142.4													
E	0050	158.5													
E	0052	164.8													
E	0054	171.0													
E	0057	183.3													
E	0062	196.7													
E	0066	213.3													
E	0072	227.1													
T7DD															
Code		[cm ³ /U]						Pump 1		Pump 2		Pump 1		Pump 2	
L	17	55.0						L	17	55.0		Q	42	132.3	
L	20	66.0						L	20	66.0		Q	45	142.4	
L	22	70.3						L	22	70.3		Q	50	158.5	
L	24	81.1						L	24	81.1		Q	52	164.8	
L	28	90.0						L	28	90.0		Q	54	171.0	
L	31	99.2						L	31	99.2		Q	57	183.3	
L	35	113.4						L	35	113.4		Q	62	196.7	
L	38	120.6						L	38	120.6		Q	66	213.3	
L	42	137.6						L	42	137.6		Q	72	227.1	

¹⁾ Code build from letter and 4 digit number.

AC20F Drive

Drive Controlled Pump

The AC20F Advanced Compact Drive is a highly featured yet economical solution to general purpose motor control applications. AC20F provides speed or torque control in the power range 1.5 kW to 180 kW. Its compact dimensions house many features normally only associated with system drives, including sensorless vector mode for control of AC induction motors, encoder feedback and IO expansion option cards, Safe Torque Off and an onboard Ethernet port that supports major industrial Ethernet protocols.

AC20F provides the perfect solution for OEM machine builders looking for a compact, cost-effective drive without compromising on performance.

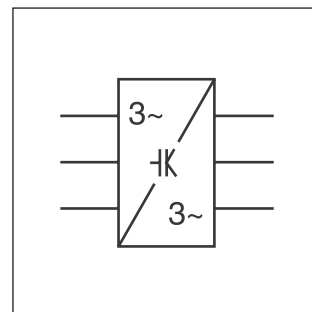

Features

- Integrated hydraulic functions
- Graphical key pad
- Integrated web server
- Sensorless vector control
- Safety torque off
- Software tool for configuration, commissioning, optimisation, programming and maintenance
- Fieldbus communication with open standards:
 - CANopen
 - PROFIBUS
 - PROFINET
 - EtherCAT
 - Ethernet IP

The following operation modes are available:

- Flow control
- Pressure control
- Alternating flow rate / pressure control (P/Q)
- eLCP (electronic load control)
- Accumulator charging mode
- Special power unit monitoring features:
 - Oil temperature
 - Oil level
 - Filter condition

Additional features on demand.

Technical data

Electrical Characteristics		
Power Supply	[VAC]	380 - 480 ±10 % Three Phase
Input Frequency	[Hz]	50/60 ±10 %
Power Range	[kW]	1.5...180 Heavy Duty (HD)
Overload		150 % for 60 sec.
Output Frequency	[Hz]	0.5...590
Max. Switching Frequency	[kHz]	10
Control Modes		Volts/Hertz, Sensorless Vector (SLV) or Closed-Loop Vector Mode (Induction only)
Supported Motors		Induction & PMAC

Environmental Characteristics		
Temperature range	[°C]	0-40 (derate possible up to 45)*
Humidity		Up to 90 % Relative Humidity, non-condensing
Vibration	[g]	< 0.5
Altitude	[m]	0-1000 (derate 1 % per 100 up to max. 2000)
Protection Degree		IP20
Pollution Degree		Category 2
Chemically Active Substances		Compliance with EN60271-3-3: C3

* without communications option fitted

More detailed technical data about the hardware is available in catalogue 192-300065 on Parker.com

Dimensions

Frame 2-5

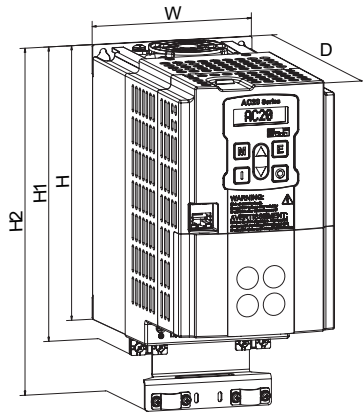

Frame 6

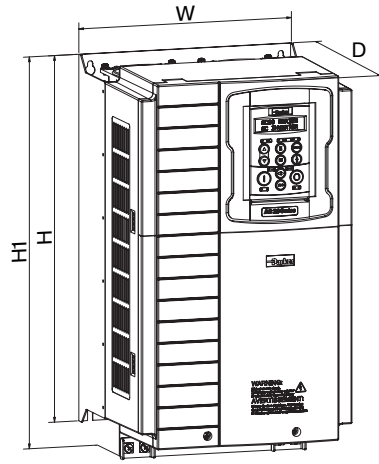

Frame 7-10

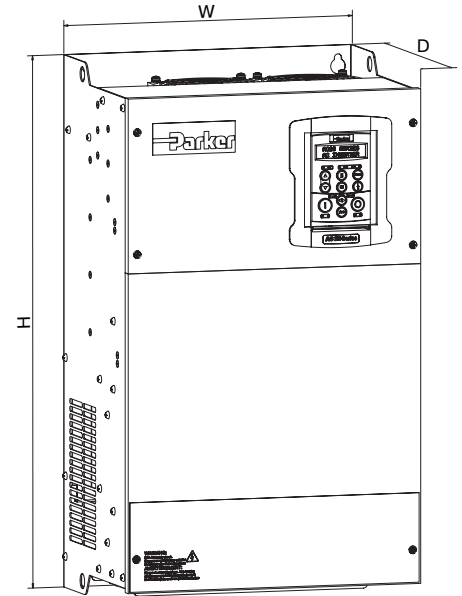

Frame	Height (H)	Height (H1)	Height (H2)	Width (W)	Depth (D)	Weight [kg]
2	180	193	227.5	108.4	185	2
3	237.5	248	281.9	141.6	184	3.3
4	265	283	321.4	161	196	4.4
5	340	358	401.4	210	220.2	8
6	435	465	n/a	262	240.5	14
7	630	623.5	n/a	355	265	42
8	765	755	n/a	406	300	56.5
9	765	778	n/a	510	326	87
10	910	925	n/a	550	341.5	123

Parker Drive System Explorer (DSE Lite)

Parker drive configuration software Drive System

Explorer (DSE) Lite is an easy to use drive configuration software package, designed to make programming your application as simple as possible without compromising on functionality.

DSE Lite is based around a straightforward block programming and an intuitive user interface which supports user-defined configurations and offers real-time monitoring and charting. DSE Lite allows the user to create, parameterize and configure user defined applications as well as parameterize and connect fixed Motor Control blocks with 70 user functions and up to 200 'links'

Thanks to the on-line help and pre-configured macro templates, users can achieve the optimum drive configuration without the need to navigate through complicated parameter menus.

DSE Lite for AC20F uses a standard Ethernet connection between PC and inverter, so no special lead is required.

Features AC20F

- Ethernet connectivity
- Network scan feature
- Drive LED identification
- Firmware installs over Ethernet
- Ability to save a project to on-board Flash memory
- Compatibility with the AC30 Series PDD scope feature.
- Power 'on the bench' for programming

It is available free of charge to download from www.parker.com.

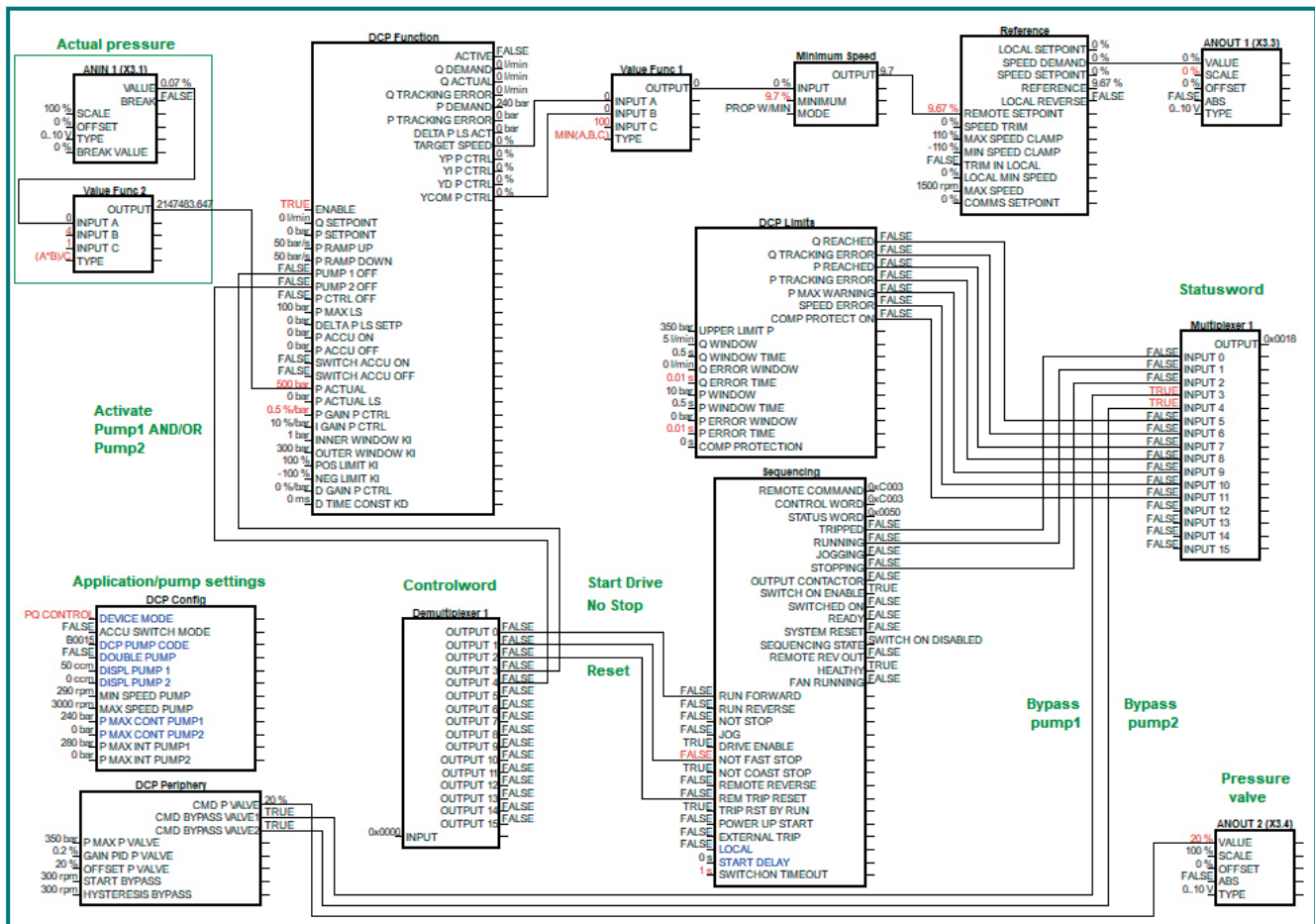

The standard asynchronous motors are characterized by their versatility, robustness and high efficiency. They fulfill the latest required efficiency standards, and therefore allow large energy savings and conserve the environment. The design offers maximum flexibility and minimum cost when installing. The comparably low weight also has a positive effect on the overall weight of the assembly.

In principal, all motors can be operated on the drive at mains voltages of up to 460 V +10 %. Operating within a power range of 1.5 to 250 kW, the motors have been designed for all markets around the world. In order to achieve the best possible design, a mix of highly conductive materials is used in the rotor. The result is minimized rotor losses and excellent start-up performance.

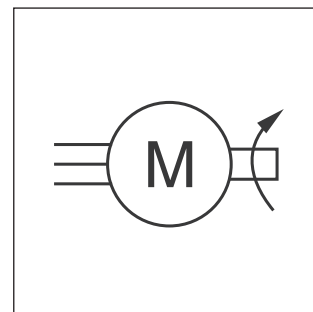
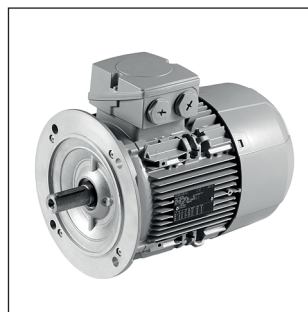

Features

- Long life-span as a result of the simplicity and robustness of the components
- Thermistor motor protection included
- Longer motor life-span thanks to lower winding temperatures in terms of the rated load and power supply
- High overload reserves in continuous operation
- Low weight

Technical data (nominal voltage 400 VAC / 50 Hz)

Code N	Rated power [kW]	Rated speed [1/min]	Efficiency factor	Rated current [A]	Rated torque [Nm]	Weight [kg]	Max. speed [1/min]	Max. torque [Nm]
1P5	1.5	1435	0.79	3.3	10	16	4200	34
2P2	2.2	1455	0.81	4.65	14	32	4200	46
003	3	1455	0.82	6.2	20	37	4200	62
004	4	1460	0.81	8.2	26	46	4200	83
006	5.5	1465	0.8	11.3	36	61	4200	104
008	7.5	1465	0.83	14.7	49	75	4200	142
011	11	1470	0.85	21	71	96	4200	198
015	15	1475	0.85	28	97	104	4200	291
019	18.5	1465	0.84	35	121	160	4200	411
022	22	1465	0.84	41.5	143	170	4200	500
030	30	1475	0.85	55	195	225	4200	604
037	37	1470	0.87	66	240	285	4500	720
045	45	1475	0.87	80	291	315	4500	902
055	55	1480	0.85	100	355	390	3700	1065
075	75	1485	0.87	132	482	560	3000	1397
090	90	1486	0.87	159	578	640	2600	1791
110	110	1490	0.86	195	705	750	2600	2115
132	132	1488	0.87	230	847	870	2600	2456
160	160	1488	0.87	280	1027	950	2600	3081
200	200	1490	0.87	350	1282	1120	2600	3974
250	250	1488	0.87	435	1605	1270	2600	5136

Vane Pumps

Drive Controlled Pump

Parker vane pumps are especially suited to variable speed applications. They enable very quick changes in pressure at a very high flow rate reproducibility and at a low noise level. Their minimum speed increases from zero proportional to pressure up to 300 rpm at maximum pressure. High operating pressures of up to 320 bar and small dimensions reduce installation costs. Reduced pressure increases life-span.

The vane pump forms a compact unit in combination with flange and e-motor. The design with two opposing pressure chambers prevents lateral forces working on the drive shaft. The pump cartridge design is suitable for drop-in installation. It is particularly modification and service friendly. The wide range of designs (displacement, shaft, connections, etc.) offers the best preconditions for individual solutions tailored to a customer's requirements.

Features

- High volumetric efficiency
- Low noise design
- High mechanical efficiency (generally over 94 %)
- Wide speed range (50–3000 rpm)
- Low pressure pulsation (±2 bar) reduces pipe noise
- Impervious to particle contamination thanks to the double lip design

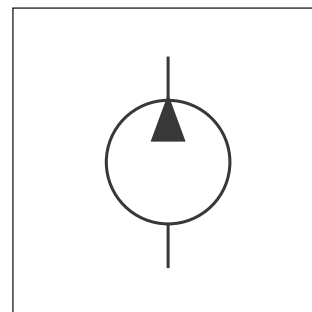
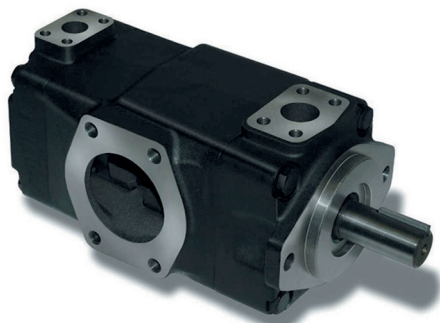

Temporary maximum pressure

The unit T7 can be operated briefly at higher pressures than the operating pressure recommended for continuous operation if the average pressure per time unit is lower than or equal to the pressure for continuous operation. The calculation formula for the temporary maximum pressure only applies when taking the other parameters into consideration – speed, operating fluid, viscosity and degree of contamination. For a total cycle duration of over 15 minutes, please get in contact with your Parker representative.

Example: B0010

Work cycle	4 mins at 320 bar
	1 mins at 35 bar
	5 mins at 160 bar

$$\frac{(4 \times 320) + (1 \times 35) + (5 \times 160)}{10} = 211.5 \text{ bar}$$

211.5 bar is lower than the operating pressure of 290 bar permitted for the continuous operation of B0010 with an HLP46 operating medium.

Technical data

Pump code	Displacement [cm ³ /U]	min. speed ¹⁾ [1/min]	max. speed [1/min]	Flow rate (1500 1/min. p 140 bar) [l/min]	max. operating pressure. permanent [bar]	max. operating pressure. temporary [bar]
B0003 - B0010	9.8 - 31.8	300	3000	14 - 46	290	320 ¹⁾
B0011 - B0014	35 - 45	300	3000	50.8 - 65.8	275	300
B0015	50	300	2700	73.3	240	280
D0017 - D0031	55 - 99.2	300	3000	75.9 - 142.2	250	300
D0035 - D0038	113.4 - 120.6	300	3000	163.5 - 174.3	250	280
D0042	137.5	300	2700	199.6	230	260
E0042 - E0072	132.3 - 227.1	300	2200	132.3 - 227.1	210	240

Internal leakage depending on pressure, speed and pump cartridge. All values applying for standard mineral oil. For more information see catalogue HY29-0001.

¹⁾ Applies to max. operating pressure only.

²⁾ Please consult Parker for applications over 300 bar.

Axial Piston Pumps

Drive Controlled Pump

Parker axial piston pumps are particularly characterized by their low noise level based on low pulsation and a rigid housing. Drops in flow that are common when operating a positive displacement pump during the compression phase are reduced by employing a pre-compression volume. In this case, the low-pressure piston is brought to operating pressure prior to entry in the pressure kidney. As soon as the piston is in the pressure range, it connects the system and pre-compression volume and refills the oil required for compressing the next piston.

In addition to significant noise reduction, axial piston pumps offer further advantages such as high efficiency, since the holding down of the pistons works without springs and with a fixed recess. They are also installation and maintenance-friendly. The axial piston pumps feature a drive shaft for single and multiple pumps.

The optimized pump design allows to keep high operating pressures up to 350 bar even at near zero speed for a longer period.

Features

- Low noise
- Short control response times
- Service friendly
- High self-priming speed
- Compact design
- The drive for 100 % nominal torque

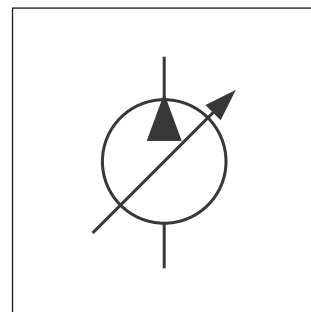
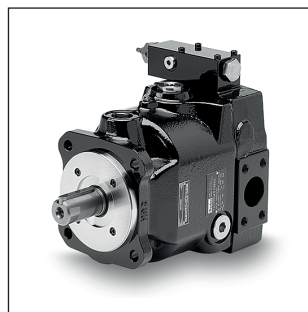

Pressure-regulated pumps with proportional pilot valve

The PVACRE..35-type proportional pilot valve is installed on the top of the controller. The electronic module PC-D00A-400 which is required for operation is included in delivery.

This version enables a variable setting of the regulated pressure between 20 and 350 bar via an electrical signal.

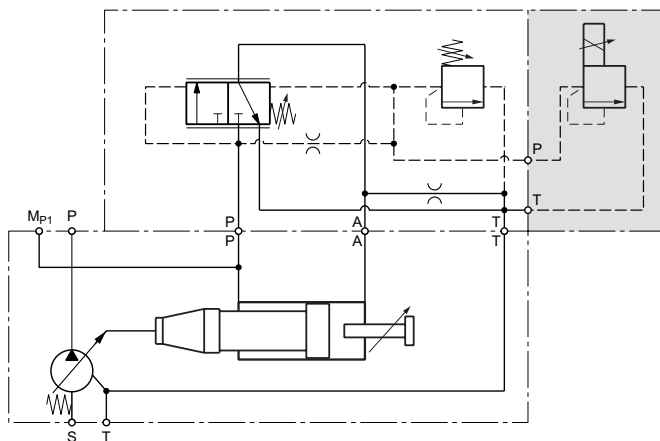

Technical data

Pump code	Displacement max. [cm³/U]	Flow rate (1500 1/min) [l/min]	Nominal pressure [bar]	Max. pressure p_{max} 20 % of work cycle [bar]	Min. input pressure absolute [bar]	Max. speed at input pressure 1 bar absolute [1/min]
PV016	16	24	350	420	0.8	3000
PV020	20	30				3000
PV023	23	34.5				3000
PV028	28	42				3000
PV032	32	48				2800
PV040	40	60				2800
PV046	46	69				2800
PV063	63	94.5				2800
PV080	80	120				2500
PV092	92	138				2300
PV140	140	210				2400
PV180	180	270				2200
PV270	270	405				1800
PV360	360	540				1750

For more information see catalogue HY30-3245

Vane pump with standard asynchronous motor

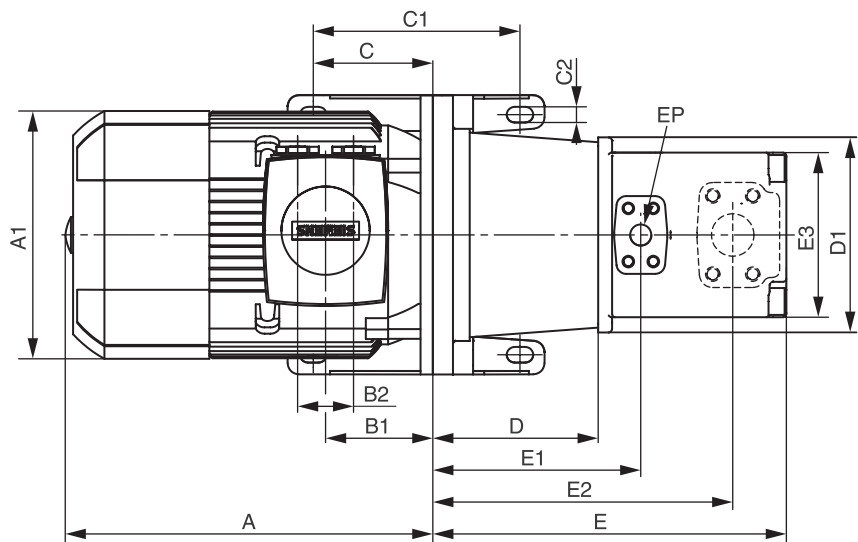
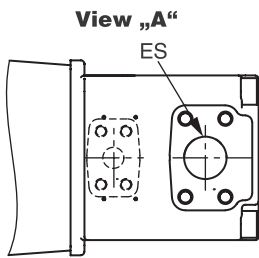
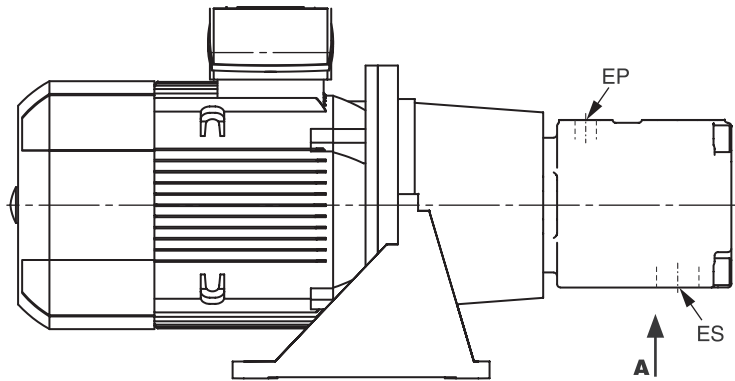
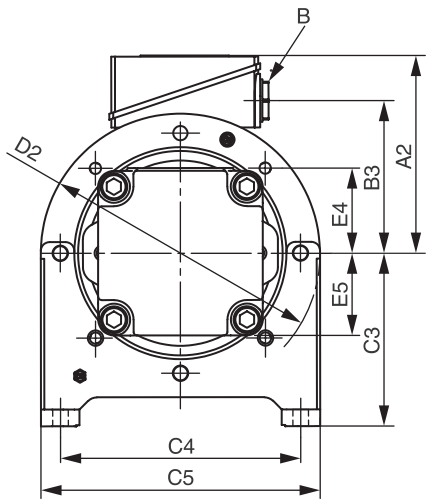

Dimensions

Drive Controlled Pump

Motor code	Pump code	Motor size	A [mm]	A1 [mm]	A2 [mm]	B [mm]	B1 [mm]	B2 [mm]	B3 [mm]	C [mm]	C1 [mm]	C2 [mm]	C3 [mm]	C4 [mm]	C5 [mm]
1P5	A0006	90L	297	178	126	1 x M25 x 1.5	78.5	0	101.5	-20	60	11	112	180	210
2P2 - 003	A0006 - 11	100L	328.5	198	193	2 x M32 x 1.5	100.5	48	147	107.5	185	14	155	215	250
004	A0006 - 11	112M	347	222	195	2 x M32 x 1.5	100.5	48	150	107.5	185	14	155	215	250
006 - 008	A0010 - 25	132S/132M	426.5	262	214.5	2 x M32 x 1.5	115.5	48	169	130.5	225	14	185	265	300
008	B0009	132M	426.5	262	214.5	2 x M32 x 1.5	115.5	48	169	130.5	225	14	185	265	300
011	A0013 - 25	160M/160L	484	314	261	2 x M40 x 1.5	145	60	213	149	265	18	235	300	350
015	A0013 - 25	160M/160L	544	314	261	2 x M40 x 1.5	145	60	213	149	265	18	235	300	350
011	B0009 - 15	160M/160L	484	314	261	2 x M40 x 1.5	145	60	213	149	265	18	235	300	350
015	B0009 - 15	160M/160L	544	314	261	2 x M40 x 1.5	145	60	213	149	265	18	235	300	350
015	D0017	160L	544	314	261	2 x M40 x 1.5	145	60	213	149	265	18	235	300	350
019 - 022	B0009 - 15	180M/180L	558	356	286	2 x M40 x 1.5	155	60	234	149	265	18	235	300	350
019 - 022	D0017 - 28	180M/180L	558	356	286	2 x M40 x 1.5	155	60	234	149	265	18	235	300	350
030	B0010 - 15	200L	636	396	315	2 x M50 x 1.5	164	85	259	174	300	18	260	350	400
030	D0020 - 38	200L	636	396	315	2 x M50 x 1.5	164	85	259	174	300	18	260	350	400
037	D0017 - 42	225S	648	449	338	2 x M50 x 1.5	164	85	282	199	335	18	295	400	450
045	D0020 - 42	225M	708	449	338	2 x M50 x 1.5	164	85	282	199	335	18	295	400	450
055	D0024 - 42	250M	747	497	410	2 x M63 x 1.5	192	110	322	249	415	18	350	500	550
075	D0028 - 42	280S	930	551	433	2 x M63 x 1.5	210	110	345	249	415	18	350	500	550
090	D0042	280M	930	551	433	2 x M63 x 1.5	210	110	345	249	415	18	350	500	550

Motor code	D [mm]	D1 [mm]	D2 [mm]	E [mm]	E1 [mm]	E2 [mm]	E3 [mm]	E4 [mm]	E5 [mm]	EP	ES
1P5	110	145	200	248.5	226.3	148.2	110	68	63.5	3/4" BSPP	1 1/4" BSPP
2P2 - 003	124	124	250	262.5	240.3	162.2	110	68	63.5	3/4" BSPP	1 1/4" BSPP
004	124	124	250	262.5	240.3	162.2	110	68	63.5	3/4" BSPP	1 1/4" BSPP
006 - 008	144	205	300	282.5	260.3	182.2	110	68	63.5	3/4" BSPP	1 1/4" BSPP
008	168	220	300	336.5	206.1	250.3	140	76.2	76.2	1" ; 4x M10 x 19 deep	1 1/2" ; 4x M12 x 22.4 deep
011 - 015	188	225	350	326.5	304.3	226.2	110	68	63.5	3/4" BSPP	1 1/4" BSPP
011 - 015	188	225	350	326.5	304.3	226.2	110	68	63.5	3/4" BSPP	1 1/4" BSPP
011 - 015	204	225	350	372.5	242.1	286.3	140	76.2	76.2	1" ; 4x M10 x 19 deep	1 1/2" ; 4x M12 x 22.4 deep
011 - 015	204	225	350	372.5	242.1	286.3	140	76.2	76.2	1" ; 4x M10 x 19 deep	1 1/2" ; 4x M12 x 22.4 deep
015	228	248	350	412.9	266.1	315.4	147.4	82.6	82.6	1 1/4" ; 4x M12 x 22.3 deep	2 1/2" ; 4x M12 x 23.9 deep
019 - 022	204	225	350	372.5	242.1	286.3	140	76.2	76.2	1" ; 4x M10 x 19 deep	1 1/2" ; 4x M12 x 22.4 deep
019 - 022	228	248	350	412.9	266.1	315.4	147.4	82.6	82.6	1 1/4" ; 4x M12 x 22.3 deep	2 1/2" ; 4x M12 x 23.9 deep
030	204	230	400	372.5	242.1	286.3	140	76.2	76.2	1" ; 4x M10 x 19 deep	1 1/2" ; 4x M12 x 22.4 deep
030	228	279	400	412.9	266.1	315.4	147.4	82.6	82.6	1 1/4" ; 4x M12 x 22.3 deep	2 1/2" ; 4x M12 x 23.9 deep
037	262	315	450	446.9	300.1	349.4	147.4	82.6	82.6	1 1/4" ; 4x M12 x 22.3 deep	2 1/2" ; 4x M12 x 23.9 deep
045	262	315	450	446.9	300.1	349.4	147.4	82.6	82.6	1 1/4" ; 4x M12 x 22.3 deep	2 1/2" ; 4x M12 x 23.9 deep
055	265	360	550	449.9	303.1	352.4	147.4	82.6	82.6	1 1/4" ; 4x M12 x 22.3 deep	2 1/2" ; 4x M12 x 23.9 deep
075	265	360	550	449.9	303.1	352.4	147.4	82.6	82.6	1 1/4" ; 4x M12 x 22.3 deep	2 1/2" ; 4x M12 x 23.9 deep
090	265	360	550	449.9	303.1	352.4	147.4	82.6	82.6	1 1/4" ; 4x M12 x 22.3 deep	2 1/2" ; 4x M12 x 23.9 deep

Pump type T7E (see ordering code) on request

1) Pressure port, BSPP or SAE 4-hole flange - J518 - ISO 6162-1
 2) Suction port, BSPP or SAE 4-hole flange - J518 - ISO 6162-1



Axial piston pump with standard asynchronous motor

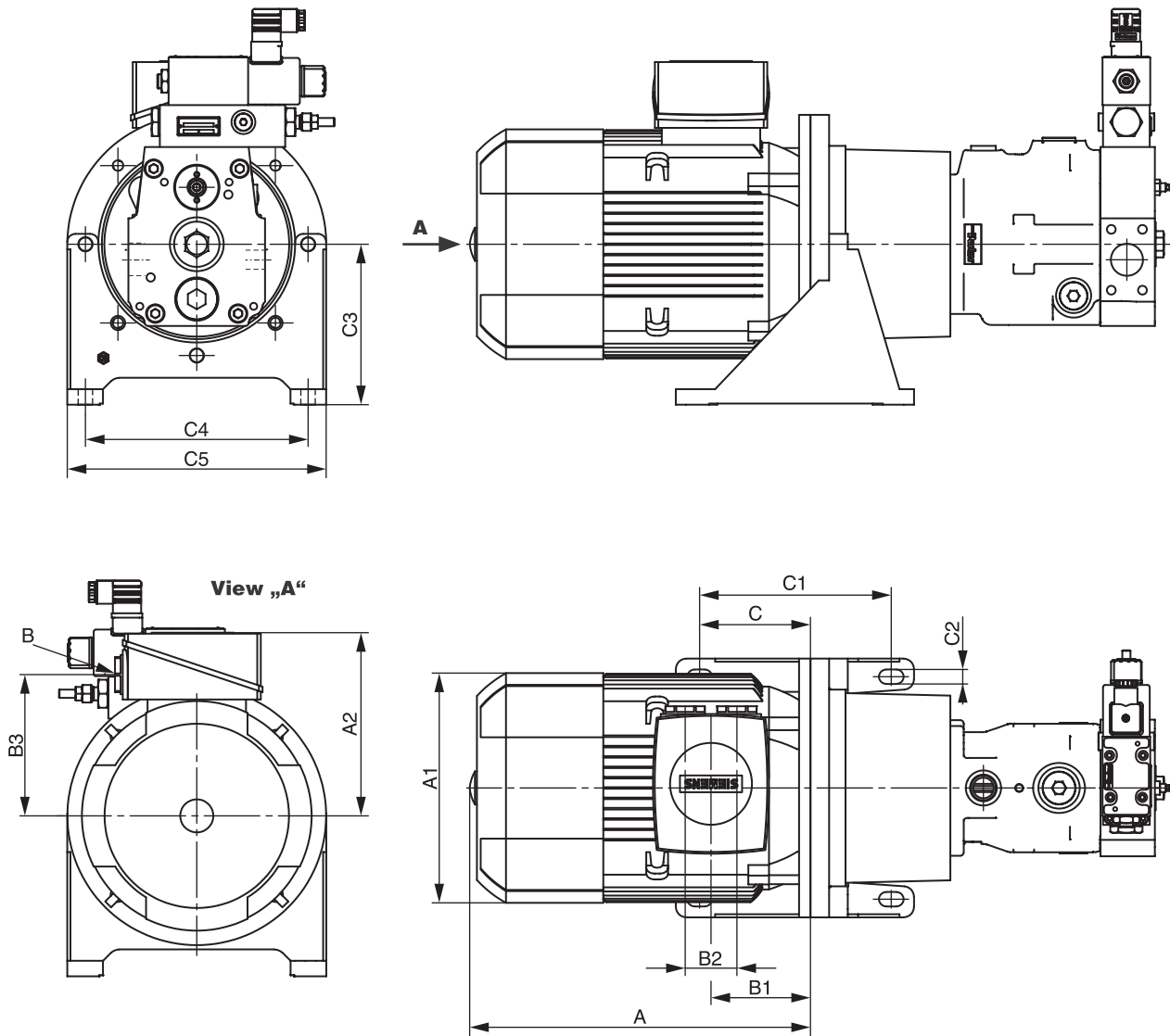

Motor code	Pump code	Motor size	A [mm]	A1 [mm]	A2 [mm]	B [mm]	B1 [mm]	B2 [mm]	B3 [mm]	C [mm]	C1 [mm]	C2 [mm]	C3 [mm]	C4 [mm]	C5 [mm]
004	P0016	112M	347	222	195	2 x M32 x 1.5	100.5	48	150	107.5	185	14	155	215	250
006 / 008	P0016 - 28	132S / 132M	426,5	262	214.5	2 x M32 x 1.5	115.5	48	169	130.5	225	14	185	265	300
011	P0016 - 28	160M / 160L	484	314	261	2 x M40 x 1.5	145	60	213	149	265	18	235	300	350
015	P0016 - 28	160M / 160L	544	314	261	2 x M40 x 1.5	145	60	213	149	265	18	235	300	350
011	P0032 - 46	160M / 160L	484	314	261	2 x M40 x 1.5	145	60	213	149	265	18	235	300	350
015	P0032 - 46	160M / 160L	544	314	261	2 x M40 x 1.5	145	60	213	149	265	18	235	300	350
019 / 022	P0020 - 28	180M / 180L	558	356	286	2 x M40 x 1.5	155	60	234	149	265	18	235	300	350
019 / 022	P0032 - 46	180M / 180L	558	356	286	2 x M40 x 1.5	155	60	234	149	265	18	235	300	350
019 / 022	P0063 / 80	180M / 180L	558	356	286	2 x M40 x 1.5	155	60	234	149	265	18	235	300	350
030	P0028	200L	636	396	315	2 x M50 x 1.5	164	85	259	174	300	18	260	350	400
030	P0032 - 46	200L	636	396	315	2 x M50 x 1.5	164	85	259	174	300	18	260	350	400
030	P0063 - 92	200L	636	396	315	2 x M50 x 1.5	164	85	259	174	300	18	260	350	400
037	P0040 - 46	225S	648	449	338	2 x M50 x 1.5	164	85	282	199	335	18	295	400	450
037	P0063 - 92	225S	648	449	338	2 x M50 x 1.5	164	85	282	199	335	18	295	400	450
037	P0140	225S	648	449	338	2 x M50 x 1.5	164	85	282	199	335	18	295	400	450
045	P0046	225M	708	449	338	2 x M50 x 1.5	164	85	282	199	335	18	295	400	450
045	P0063 - 92	225M	708	449	338	2 x M50 x 1.5	164	85	282	199	335	18	295	400	450
045	P0140 - 180	225M	708	449	338	2 x M50 x 1.5	164	85	282	199	335	18	295	400	450
055	P0063 - 092	250M	747	497	410	2 x M63 x 1.5	192	110	322	249	415	18	350	500	550
055	P0140 - 180	250M	747	497	410	2 x M63 x 1.5	192	110	322	249	415	18	350	500	550
075	P0080 - 092	280S	930	551	433	2 x M63 x 1.5	210	110	345	249	415	18	350	500	550
075	P0140 - 180	280S	930	551	433	2 x M63 x 1.5	210	110	345	249	415	18	350	500	550
075	P0270	280S	930	551	433	2 x M63 x 1.5	210	110	345	249	415	18	350	500	550
090	P0092	280M	930	551	433	2 x M63 x 1.5	210	110	345	249	415	18	350	500	550
090	P0140 - 180	280M	930	551	433	2 x M63 x 1.5	210	110	345	249	415	18	350	500	550
090	P0270	280M	930	551	433	2 x M63 x 1.5	210	110	345	249	415	18	350	500	550
090	P0360	280M	930	551	433	2 x M63 x 1.5	210	110	345	249	415	18	350	500	550
110	P0140 - 180	315S	1077	616	515	2 x M63 x 1.5	238	110	404	298.5	495	22	380	600	660
110	P0270	315S	1077	616	515	2 x M63 x 1.5	238	110	404	298.5	495	22	380	600	660
110	P0360	315S	1077	616	515	2 x M63 x 1.5	238	110	404	298.5	495	22	380	600	660
132	P0140 - 180	315M	1077	616	515	2 x M63 x 1.5	238	110	404	298.5	495	22	380	600	660
132	P0270	315M	1077	616	515	2 x M63 x 1.5	238	110	404	298.5	495	22	380	600	660
132	P0360	315M	1077	616	515	2 x M63 x 1.5	238	110	404	298.5	495	22	380	600	660
160	P0180	315L	1232	616	515	2 x M63 x 1.5	238	110	404	298.5	495	22	380	600	660
160	P0270	315L	1232	616	515	2 x M63 x 1.5	238	110	404	298.5	495	22	380	600	660
160	P0360	315L	1232	616	515	2 x M63 x 1.5	238	110	404	298.5	495	22	380	600	660
200 - 250	P0270	315L	1232	616	515	2 x M63 x 1.5	238	110	404	298.5	495	22	380	600	660
200 - 250	P0360	315L	1232	616	515	2 x M63 x 1.5	238	110	404	298.5	495	22	380	600	660

continuing next page 

Axial piston pump with standard asynchronous motor

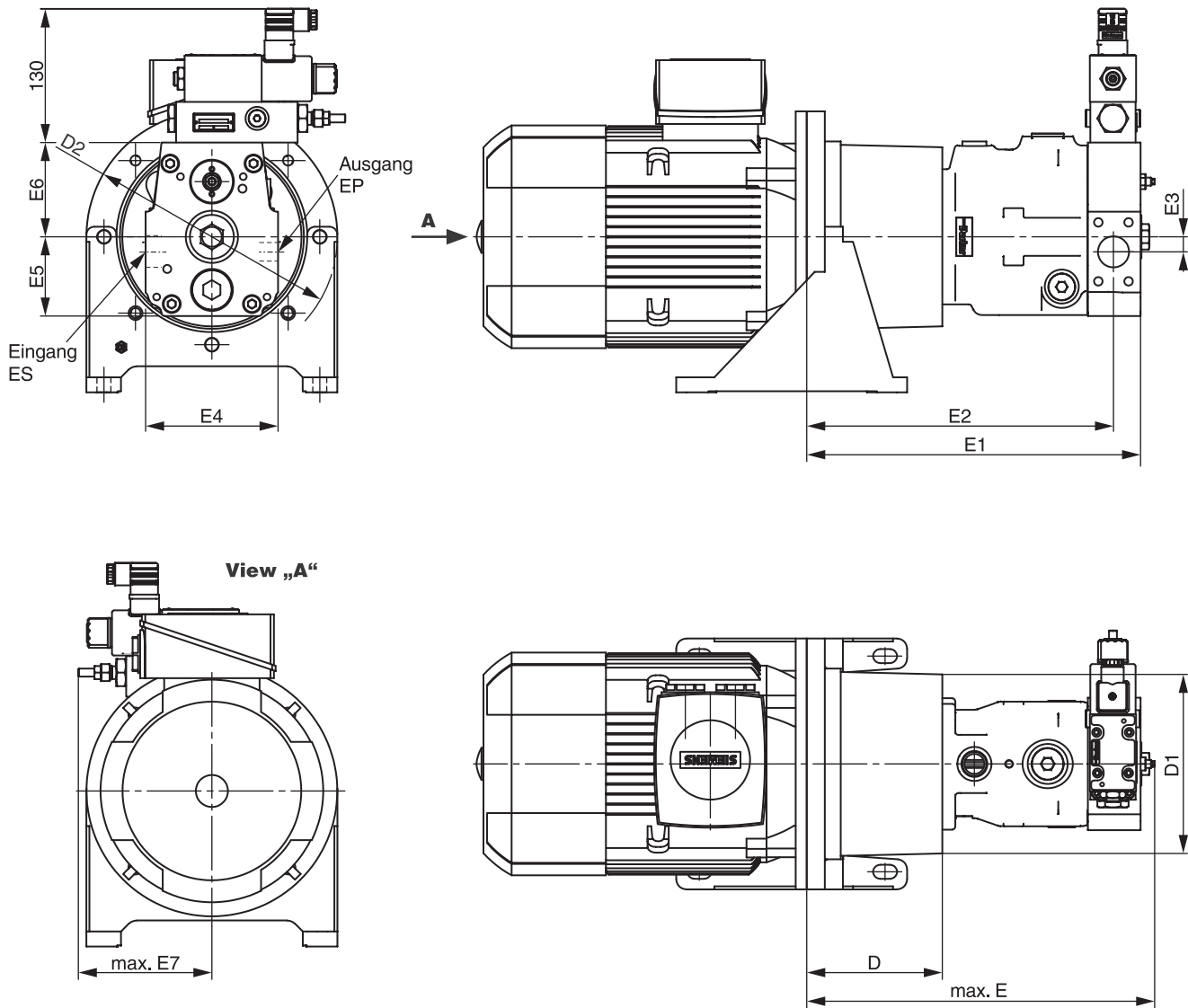

Motor code	Pump code	D [mm]	D1 [mm]	D2 [mm]	E [mm]	E1 [mm]	E2 [mm]	E3 [mm]	E4 [mm]	E5 [mm]	E6 [mm]	E7 [mm]	EP (PN 400 bar)	ES
004	P0016	135	180	250	347	332.5	305.5	15	132	79	94	130	DN19 ; 4xM10x18 deep	DN32 ; PN 250 bar ; 4xM10x18 deep
006 / 008	P0016 - 28	155	205	300	367	352.5	325.5	15	132	79	94	130	DN19 ; 4xM10x18 deep	DN32 ; PN 250 bar ; 4xM10x18 deep
011 / 015	P0016 - 28	188	225	350	400	385.5	358.5	15	132	79	94	130	DN19 ; 4xM10x18 deep	DN32 ; PN 250 bar ; 4xM10x18 deep
011 / 015	P0032 - 46	204	225	350	452	431	401	17	160	97	112.5	130	DN25 ; 4xM12x18 deep	DN38 ; PN 200 bar ; 4xM12x18 deep
019 / 022	P0020 - 28	204	225	350	416	401.5	374.5	15	132	79	94	130	DN19 ; 4xM10x18 deep	DN32 ; PN 250 bar ; 4xM10x18 deep
019 / 022	P0032 - 46	204	225	350	452	431	401	17	160	97	112.5	130	DN25 ; 4xM12x18 deep	DN38 ; PN 200 bar ; 4xM12x18 deep
019 / 022	P0063 / 80	228	248	350	536	515	480	26	200	120	132	133	DN32 ; 4xM12x20 deep	DN51 ; PN 200 bar ; 4xM12x20 deep
030	P0028	204	230	400	416	401.5	374.5	15	132	79	94	130	DN19 ; 4xM10x18 deep	DN32 ; PN 250 bar ; 4xM10x18 deep
030	P0032 - 46	204	230	400	452	431	401	17	160	97	112.5	130	DN25 ; 4xM12x18 deep	DN38 ; PN 200 bar ; 4xM12x18 deep
030	P0063 - 92	228	279	400	536	515	480	26	200	120	132	133	DN32 ; 4xM12x20 deep	DN51 ; PN 200 bar ; 4xM12x20 deep
037	P0040 - 46	234	260	450	482	461	431	17	160	97	112.5	130	DN25 ; 4xM12x18 deep	DN38 ; PN 200 bar ; 4xM12x18 deep
037	P0063 - 92	262	315	450	570	549	514	26	200	120	132	133	DN32 ; 4xM12x20 deep	DN51 ; PN 200 bar ; 4xM12x20 deep
037	P0140	262	315	450	648	612	557 *)	0	200	145	158	133	DN32 ; 4xM12x20 deep	DN64 ; PN 160 bar ; 4xM12x20 deep
045	P0046	234	260	450	482	461	431	17	160	97	112.5	130	DN25 ; 4xM12x18 deep	DN38 ; PN 200 bar ; 4xM12x18 deep
045	P0063 - 92	262	315	450	570	549	514	26	200	120	132	133	DN32 ; 4xM12x20 deep	DN51 ; PN 200 bar ; 4xM12x20 deep
045	P0140 - 180	262	315	450	648	612	557 *)	0	200	145	158	133	DN32 ; 4xM12x20 deep	DN64 ; PN 160 bar ; 4xM12x20 deep
055	P0063 - 92	265	360	550	573	552	517	26	200	120	132	133	DN32 ; 4xM12x20 deep	DN51 ; PN 200 bar ; 4xM12x20 deep
055	P0140 - 180	265	360	550	651	615	560 *)	0	200	145	158	133	DN32 ; 4xM12x20 deep	DN64 ; PN 160 bar ; 4xM12x20 deep
075	P0080 - 92	265	360	550	573	552	517	26	200	120	132	133	DN32 ; 4xM12x20 deep	DN51 ; PN 200 bar ; 4xM12x20 deep
075	P0140 - 180	265	360	550	651	615	560 *)	0	200	145	158	133	DN32 ; 4xM12x20 deep	DN64 ; PN 160 bar ; 4xM12x20 deep
075	P0270	295	360	550	805	767.5	698	0	265	176	184	133	DN38 ; 4xM16x30 deep	DN89 ; PN 35 bar ; 4xM16x30 deep
090	P0092	265	360	550	573	552	517	26	200	120	132	133	DN32 ; 4xM12x20 deep	DN51 ; PN 200 bar ; 4xM12x20 deep
090	P0140 - 180	265	360	550	651	615	560 *)	0	200	145	158	133	DN32 ; 4xM12x20 deep	DN64 ; PN 160 bar ; 4xM12x20 deep
090	P0270	295	360	550	805	767.5	698	0	265	176	184	133	DN38 ; 4xM16x30 deep	DN89 ; PN 35 bar ; 4xM16x30 deep
090	P0360	315	400	550	825	792	723	0	250	176	184	133	DN38 ; 4xM16x30 deep	DN102 ; PN 35 bar ; 4xM16x30 deep
110	P0140 - 180	310	410	660	696	660	605 *)	0	200	145	158	133	DN32 ; 4xM12x20 deep	DN64 ; PN 160 bar ; 4xM12x20 deep
110	P0270	330	400	660	840	802.5	733	0	265	176	184	133	DN38 ; 4xM16x30 deep	DN89 ; PN 35 bar ; 4xM16x30 deep
110	P0360	330	400	660	840	807	738	0	250	176	184	133	DN38 ; 4xM16x30 deep	DN102 ; PN 35 bar ; 4xM16x30 deep
132	P0140 - 180	310	410	660	696	660	605 *)	0	200	145	158	133	DN32 ; 4xM12x20 deep	DN64 ; PN 160 bar ; 4xM12x20 deep
132	P0270	310	410	660	696	660	605	0	200	145	158	133	DN32 ; 4xM12x20 deep	DN64 ; PN 160 bar ; 4xM12x20 deep
132	P0360	330	400	660	840	802.5	733	0	265	176	184	133	DN38 ; 4xM16x30 deep	DN89 ; PN 35 bar ; 4xM16x30 deep
160	P0180	330	400	660	840	807	738 *)	0	250	176	184	133	DN38 ; 4xM16x30 deep	DN102 ; PN 35 bar ; 4xM16x30 deep
160	P0270	330	400	660	716	680	625	0	200	145	158	133	DN32 ; 4xM12x20 deep	DN64 ; PN 160 bar ; 4xM12x20 deep
160	P0360	330	400	660	840	802.5	733	0	265	176	184	133	DN38 ; 4xM16x30 deep	DN89 ; PN 35 bar ; 4xM16x30 deep
200 - 250	P0270	330	400	660	840	802.5	733	0	265	176	184	133	DN38 ; 4xM16x30 deep	DN89 ; PN 35 bar ; 4xM16x30 deep
200 - 250	P0360	330	400	660	840	807	738	0	250	176	184	133	DN38 ; 4xM16x30 deep	DN102 ; PN 35 bar ; 4xM16x30 deep

EP: Pressure port, flange acc. to ISO 6162

ES: Suction port, flange acc. to ISO 6162

¹⁾ Dimension for suction port +10 mm

Dimensions

Drive Controlled Pump

Double vane pump with standard asynchronous motor

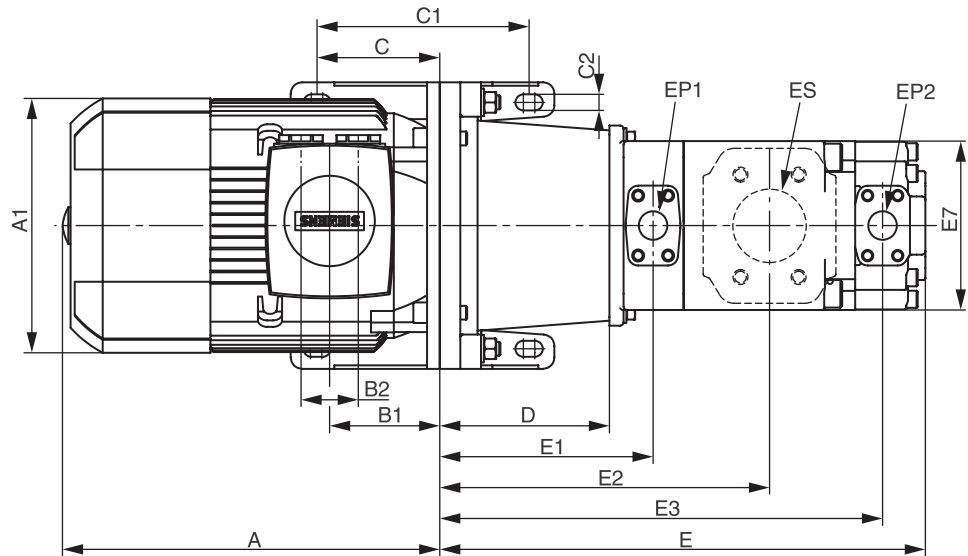
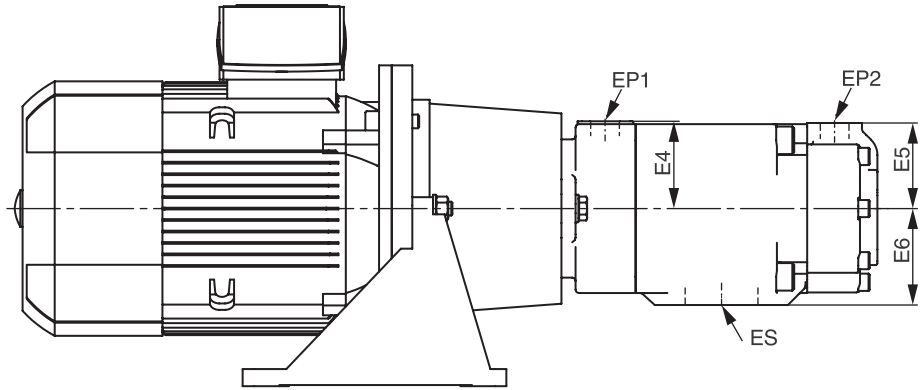
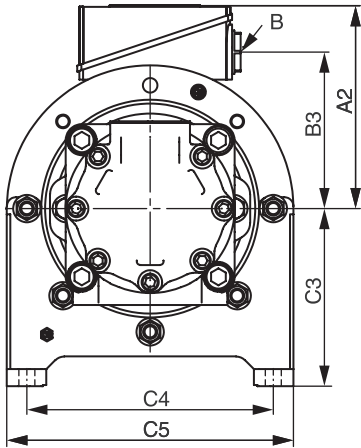

Motor code	Motor size	Pump code	A [mm]	A1 [mm]	A2 [mm]	B [mm]	B1 [mm]	B2 [mm]	B3 [mm]	C [mm]	C1 [mm]	C2 [mm]	C3 [mm]	C4 [mm]	C5 [mm]	D [mm]	D1 [mm]	D2 [mm]
004	112M	J****	347	222	195	2 x M32 x 1.5	100.5	48	150	107.5	185	14	155	215	250	148	166	250
006 - 008	132S/132M	J****	426.5	262	214.5	2 x M32 x 1.5	115.5	48	169	130.5	225	14	185	265	300	168	220	300
011	160M/160L	J****	484	314	261	2 x M40 x 1.5	145	60	213	149	265	18	235	300	350	204	225	350
015	160M/160L	J****	544	314	261	2 x M40 x 1.5	145	60	213	149	265	18	235	300	350	204	225	350
011	160M/160L	K****	484	314	261	2 x M40 x 1.5	145	60	213	149	265	18	235	300	350	228	248	350
015	160M/160L	K****	544	314	261	2 x M40 x 1.5	145	60	213	149	265	18	235	300	350	228	248	350
015	160L	L****	544	314	261	2 x M40 x 1.5	145	60	213	149	265	18	235	300	350	228	248	350
019 - 022	180M/180L	J****	558	356	286	2 x M40 x 1.5	155	60	234	149	265	18	235	300	350	204	225	350
019 - 022	180M/180L	K****	558	356	286	2 x M40 x 1.5	155	60	234	149	265	18	235	300	350	228	248	350
019 - 022	180M/180L	L****	558	356	286	2 x M40 x 1.5	155	60	234	149	265	18	235	300	350	228	248	350
030	200L	J****	636	396	315	2 x M50 x 1.5	164	85	259	174	300	18	260	350	400	204	230	400
030	200L	K****	636	396	315	2 x M50 x 1.5	164	85	259	174	300	18	260	350	400	228	279	400
030	200L	L****	636	396	315	2 x M50 x 1.5	164	85	259	174	300	18	260	350	400	228	279	400
037	225S	J****	648	449	338	2 x M50 x 1.5	164	85	282	199	335	18	295	400	450	262	315	450
037	225S	K****	648	449	338	2 x M50 x 1.5	164	85	282	199	335	18	295	400	450	262	315	450
037	225S	L****	648	449	338	2 x M50 x 1.5	164	85	282	199	335	18	295	400	450	234	260	450
045	225M	J****	708	449	338	2 x M50 x 1.5	164	85	282	199	335	18	295	400	450	262	315	450
045	225M	K****	708	449	338	2 x M50 x 1.5	164	85	282	199	335	18	295	400	450	262	315	450
045	225M	L****	708	449	338	2 x M50 x 1.5	164	85	282	199	335	18	295	400	450	234	260	450
055	250M	J****	747	497	410	2 x M63 x 1.5	192	110	322	249	415	18	350	500	550	248	340	550
055	250M	K****	747	497	410	2 x M63 x 1.5	192	110	322	249	415	18	350	500	550	265	450	550
055	250M	L****	747	497	410	2 x M63 x 1.5	192	110	322	249	415	18	350	500	550	265	450	550
075	280S	J****	930	551	433	2 x M63 x 1.5	210	110	345	249	415	18	350	500	550	265	450	550
075 - 090	280S/280M	K****	930	551	433	2 x M63 x 1.5	210	110	345	249	415	18	350	500	550	265	450	550
075 - 090	280S/280M	L****	930	551	433	2 x M63 x 1.5	210	110	345	249	415	18	350	500	550	265	360	550
110	315S	K****	1077	616	515	2 x M63 x 1.5	238	110	404	249	415	18	350	500	550	265	450	550
110	315S	L****	1077	616	515	2 x M63 x 1.5	238	110	404	298.5	495	22	380	600	660	310	410	660
132 - 160	315M/315L	L****	1232	616	515	2 x M63 x 1.5	238	110	404	298.5	495	22	380	600	660	310	410	660

Motor code	E [mm]	E1 [mm]	E2 [mm]	E3 [mm]	E4 [mm]	E5 [mm]	E6 [mm]	E7 [mm]	EP1	EP2	ES
004	410.4	186.1	287.7	386.3	76.2	74.7	84.1	140	1"; 4x M10 x 19 deep	1"; 4x M10 x 19 deep	2 1/2"; 4x M12x 22.4 deep
006 - 008	430.4	206.1	307.7	406.3	76.2	74.7	84.1	140	1"; 4x M10 x 19 deep	1"; 4x M10 x 19 deep	2 1/2"; 4x M12x 22.4 deep
011	466.4	242.1	343.7	442.3	76.2	74.7	84.1	140	1"; 4x M10 x 19 deep	1"; 4x M10 x 19 deep	2 1/2"; 4x M12x 22.4 deep
015	466.4	242.1	343.7	442.3	76.2	74.7	84.1	140	1"; 4x M10 x 19 deep	1"; 4x M10 x 19 deep	2 1/2"; 4x M12x 22.4 deep
011	514	266.1	380.4	489.9	82.6	74.7	88.9	182	1 1/4"; 4x M12 x 22.3 deep	1"; 4x M10 x 19 deep	3"; 4x M16 x 28.4 deep
015	514	266.1	380.4	489.9	82.6	74.7	88.9	182	1 1/4"; 4x M12 x 22.3 deep	1"; 4x M10 x 19 deep	3"; 4x M16 x 28.4 deep
015	575.7	266.3	414.6	548.8	101.6	101.6	114.9	182	1 1/4"; 4x M12 x 22.3 deep	1 1/4"; 4x M12 x 24 deep	4"; 4x M16 x 30 deep
019 - 022	466.4	242.1	343.7	442.3	76.2	74.7	84.1	140	1"; 4x M10 x 19 deep	1"; 4x M10 x 19 deep	2 1/2"; 4x M12x 22.4 deep
019 - 022	514	266.1	380.4	489.9	82.6	74.7	88.9	182	1 1/4"; 4x M12 x 22.3 deep	1"; 4x M10 x 19 deep	3"; 4x M16 x 28.4 deep
019 - 022	575.7	266.3	414.6	548.8	101.6	101.6	114.9	182	1 1/4"; 4x M12 x 22.3 deep	1 1/4"; 4x M12 x 24 deep	4"; 4x M16 x 30 deep
030	466.4	242.1	343.7	442.3	76.2	74.7	84.1	140	1"; 4x M10 x 19 deep	1"; 4x M10 x 19 deep	2 1/2"; 4x M12x 22.4 deep
030	514	266.1	380.4	489.9	82.6	74.7	88.9	182	1 1/4"; 4x M12 x 22.3 deep	1"; 4x M10 x 19 deep	3"; 4x M16 x 28.4 deep
030	575.7	266.3	414.6	548.8	101.6	101.6	114.9	182	1 1/4"; 4x M12 x 22.3 deep	1 1/4"; 4x M12 x 24 deep	4"; 4x M16 x 30 deep
037	524.4	300.1	401.7	500.3	76.2	74.7	84.1	140	1"; 4x M10 x 19 deep	1"; 4x M10 x 19 deep	2 1/2"; 4x M12x 22.4 deep
037	548	300.1	414.4	523.9	82.6	74.7	88.9	182	1 1/4"; 4x M12 x 22.3 deep	1"; 4x M10 x 19 deep	3"; 4x M16 x 28.4 deep
037	581.7	272.3	420.6	554.8	101.6	101.6	114.9	182	1 1/4"; 4x M12 x 22.3 deep	1 1/4"; 4x M12 x 24 deep	4"; 4x M16 x 30 deep
045	524.4	300.1	401.7	500.3	76.2	74.7	84.1	140	1"; 4x M10 x 19 deep	1"; 4x M10 x 19 deep	2 1/2"; 4x M12x 22.4 deep
045	548	300.1	414.4	523.9	82.6	74.7	88.9	182	1 1/4"; 4x M12 x 22.3 deep	1"; 4x M10 x 19 deep	3"; 4x M16 x 28.4 deep
045	581.7	272.3	420.6	554.8	101.6	101.6	114.9	182	1 1/4"; 4x M12 x 22.3 deep	1 1/4"; 4x M12 x 24 deep	4"; 4x M16 x 30 deep
055	510.4	286.1	387.7	486.3	76.2	74.7	84.1	140	1"; 4x M10 x 19 deep	1"; 4x M10 x 19 deep	2 1/2"; 4x M12x 22.4 deep
055	551	303.1	417.4	526.9	82.6	74.7	88.9	182	1 1/4"; 4x M12 x 22.3 deep	1"; 4x M10 x 19 deep	3"; 4x M16 x 28.4 deep
055	612.7	303.3	451.6	585.8	101.6	101.6	114.9	182	1 1/4"; 4x M12 x 22.3 deep	1 1/4"; 4x M12 x 24 deep	4"; 4x M16 x 30 deep
075	527.4	303.1	404.7	503.3	76.2	74.7	84.1	140	1"; 4x M10 x 19 deep	1"; 4x M10 x 19 deep	2 1/2"; 4x M12x 22.4 deep
075 - 090	551	303.1	417.4	526.9	82.6	74.7	88.9	182	1 1/4"; 4x M12 x 22.3 deep	1"; 4x M10 x 19 deep	3"; 4x M16 x 28.4 deep
075 - 090	612.7	303.3	451.6	585.8	101.6	101.6	114.9	182	1 1/4"; 4x M12 x 22.3 deep	1 1/4"; 4x M12 x 24 deep	4"; 4x M16 x 30 deep
110	551	303.1	417.4	526.9	82.6	74.7	88.9	182	1 1/4"; 4x M12 x 22.3 deep	1"; 4x M10 x 19 deep	3"; 4x M16 x 28.4 deep
110	657.7	348.3	496.6	630.8	101.6	101.6	114.9	182	1 1/4"; 4x M12 x 22.3 deep	1 1/4"; 4x M12 x 24 deep	4"; 4x M16 x 30 deep
132 - 160	657.7	348.3	496.6	630.8	101.6	101.6	114.9	182	1 1/4"; 4x M12 x 22.3 deep	1 1/4"; 4x M12 x 24 deep	4"; 4x M16 x 30 deep

Pump types T7EB, T7ED and T7EE (see ordering code) on request

EP* : Pressure ports, SAE 4-hole flange - J518 - ISO 6162-1

ES : Suction ports, SAE 4-hole flange - J518 - ISO 6162-1

www.parker.com



European Headquarters
La Tuilière 6, 1163 Etoy,
Switzerland
Tel: +41 21 821 85 00

Your authorized Distributor